

RESEARCH. EVALUATION. INNOVATION. SOLUTION.

 CALGAVIN

DELIVERING SOLUTIONS FROM STUDY TO REVAMP





FORMED OVER 30 YEARS AGO, CALGAVIN IS A GLOBAL MARKET LEADER IN HEAT EXCHANGE ENGINEERING.

With experience from more than 16,000 projects worldwide, we are able to offer you the best technical advice available. This is backed up by ongoing investment in Research & Development and our collaboration in numerous industry initiatives to improve heat transfer technology and practice.

WE WORK IN ALL AREAS WHERE HEAT EXCHANGERS ARE USED, BUT OUR CORE SECTORS ARE:

- OIL AND GAS
- PETROCHEMICALS
- CHEMICALS
- POWER GENERATION

Clients include leading processors such as **BP, Shell, ExxonMobil, Lukoil, BASF, Dow** and **Lanxess**.

Alongside our world-class enhancement product range, including market leading **hiTRAN** Thermal Systems, we provide practical and objective consultancy advice on improving the operation of your plant. As engineers ourselves we fully understand the many operating issues that you face. **CALGAVIN'S** role is to provide technical solutions specific to the needs of each unique process. Our objective is to fully support you in optimising your production.

You can be confident in our quality, which is backed by ISO 9001 certification.



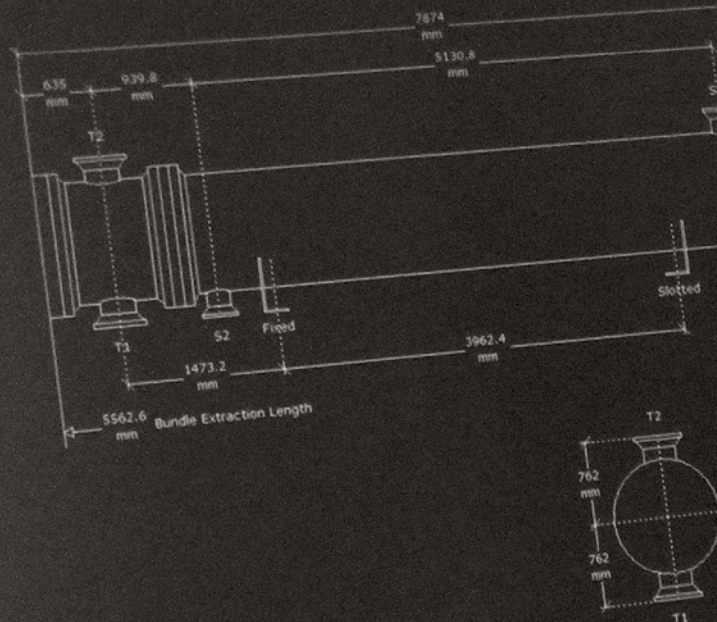

ADDED VALUE ENGINEERING

CALGAVIN PLACES A WEALTH OF HEAT EXCHANGE ENGINEERING EXPERTISE AT YOUR DISPOSAL.

Working with **CALGAVIN** from an early stage of your project will bring key benefits in optimising plant performance. Our engineers use state-of-the-art heat transfer and process software such as AspenTech and always incorporate best practice in heat exchange engineering.

CALGAVIN ADDS VALUE BY PROVIDING THE EXPERT SERVICES YOU NEED, WHEN YOU NEED THEM:

- HEAT EXCHANGER RATING AND RE-RATING
- DESIGN REVIEW AND OPTIMISATION
- PERFORMANCE MEASUREMENT AND ANALYSIS
- TROUBLESHOOTING
- DEBOTTLENECKING
- PROCESS INTEGRATION ANALYSIS
- CUSTOMISED MODELLING

Whether your objectives are optimised production, improved reliability or increased energy efficiency, we will provide expert support to your project and help you to deliver your goals.

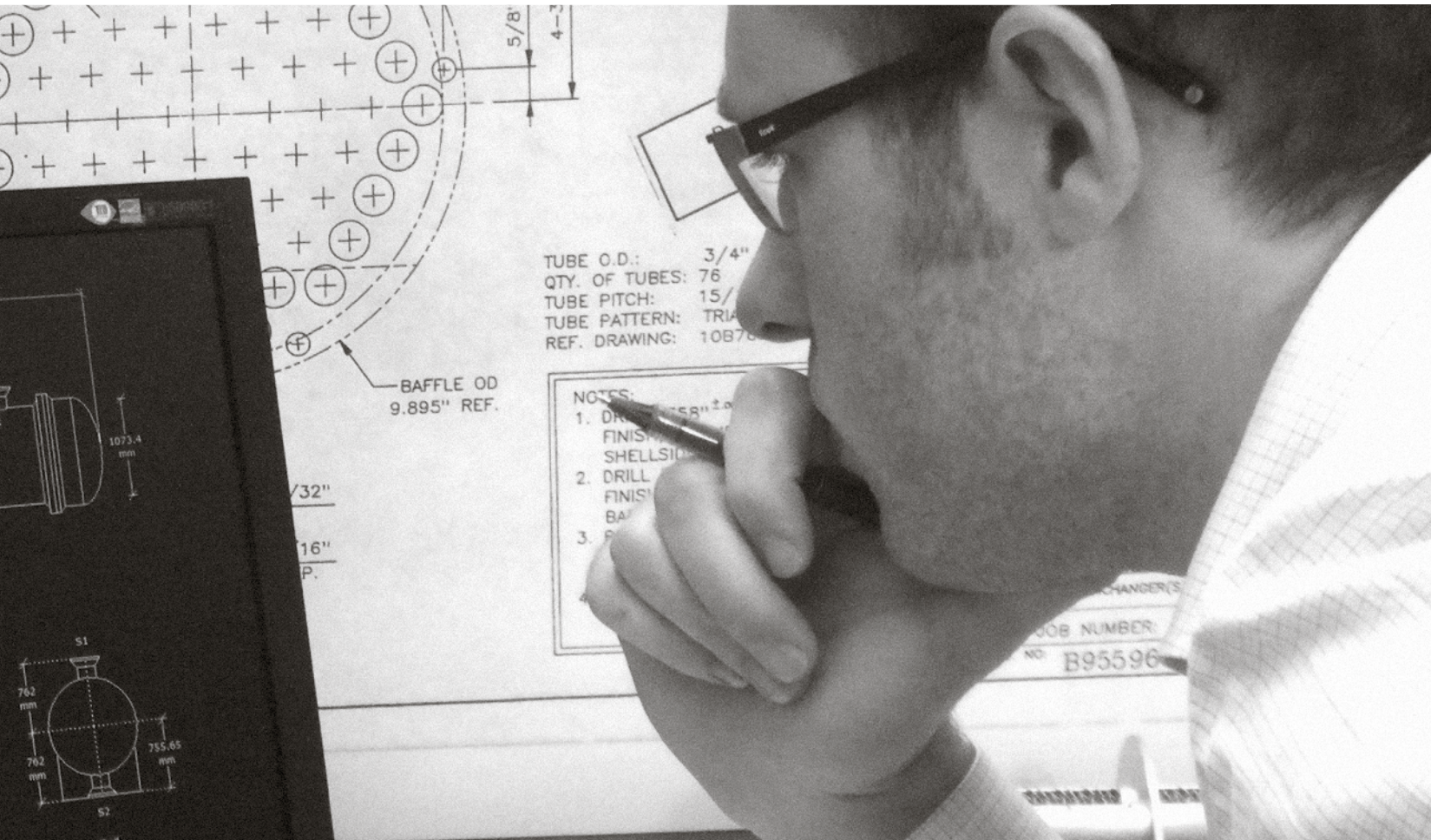

WE SOLVE PROBLEMS

A REFINERY

Limited performance of a multi-shell two phase feed/ effluent arrangement caused high fuel consumption and hindered plant capacity increase.

CALGAVIN engineers confirmed that poor heat transfer limited the performance with maldistribution, due to low pressure loss, partly to blame. Exchanger enhancement technology, tailored to suit the changing proportions of liquid and vapour through the exchangers was installed during a scheduled shutdown.

This feed/ effluent exchanger retrofit enabled higher throughput and reduced energy consumption by 4.6MW, (full flow) saving Lukoil Refinery more than US\$ 0.5M/year.

Image courtesy of Lukoil, Volgograd, Russia





INNOVATIVE PRODUCTS & SOLUTIONS

CALGAVIN'S LONG-TERM COMMITMENT TO RESEARCH AND DEVELOPMENT, AND OUR PASSION FOR INNOVATION, HAVE RESULTED IN A RANGE OF PRODUCTS DESIGNED TO MAKE THE MOST OF YOUR HEAT EXCHANGER INVESTMENT.

Our products range from simple devices which enhance heating and cooling to complex solutions which accelerate condensation and boiling processes. All our products are robustly engineered for demanding environments and are backed by many years of research and testing. **CALGAVIN** works continuously with respected universities and research organisations to develop new products and verify specific applications.





OUR PRODUCTS ARE INSTALLED IN HUNDREDS OF PLANTS WORLDWIDE AND ARE TRUSTED BY LEADING EXCHANGER MANUFACTURERS INCLUDING:

Jord International

Doosan

Bronswerk Heat Transfer

GEA Heat Exchangers

Nuovo Pignone (GE)

Borkhimmash

Harsco Industrial Air-X-Changers

KNM

Oeltechnik

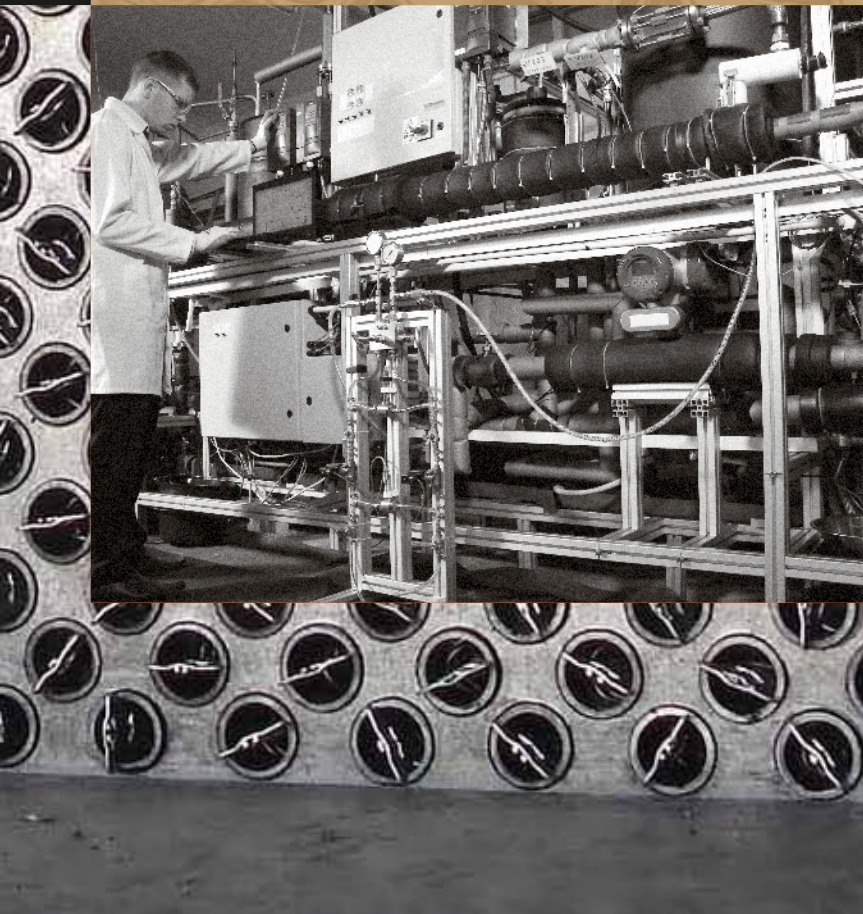

Temperature

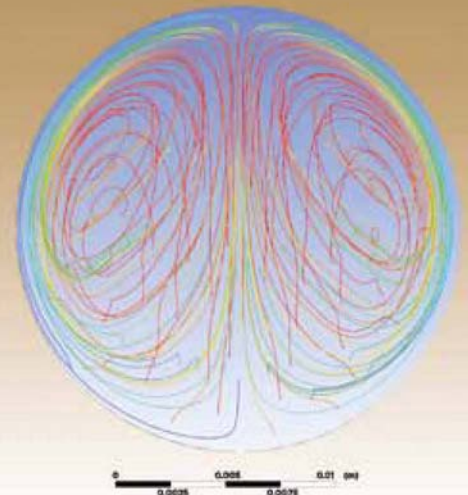
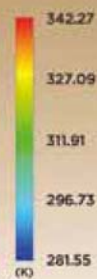

WHY WE ARE CONFIDENT

"We thank Calgavin staff for their professionalism and competence"

First General Deputy Director, **Lukoil**



- Our independent approach means that we are able to offer you objective advice that is the best for your specific business.
- You are in safe hands - our proven track record includes such clients as Total, Pemex, ONGC, Aventis, Saudi Aramco, Petronas, GE Plastics and Chevron.
- Our ongoing Research and Development investment and our skilled and experienced engineers mean that we stay at the cutting edge of technology to support you.
- We can identify solutions, or help you implement your own plans.
- Your business needs will be met wherever you are in the world through our network of offices and partners.



- Our experience embraces many industries so we are confident that we can help with all of your heat exchange issues.
- We really do understand your needs, we have delivered solutions to the process industry for over 30 years.
- With thousands of projects successfully completed, we offer you unrivalled technical expertise.

YOUR WORLDWIDE PARTNER FOR HEAT EXCHANGE



CANADA

IMPROVED SUMMER COOLING
PERFORMANCE AT GAS
SWEETENING PLANT



U.S.A.

RE-ENGINEERED HEAT EXCHANGER
RESOLVES CORROSION PROBLEM



MEXICO

COMPACT HEAT TRANSFER SOLUTION
FOR OIL/WATER SEPARATION PLANT



ANGOLA

OPTIMISED HEAT EXCHANGERS
IMPROVE CONGESTED FPSO LAYOUT



MALAYSIA

EVAPORATOR LIQUID CARRYOVER ISSUE
RESOLVED - 100% VAPORISATION ACHIEVED



INDIA

PRECISE CONTROL OF WALL TEMPERATURES
REDUCES FOULING AND EXTENDS RUN TIME



UK



PROBLEMS SOLVED ON REACTOR COOLER

SAUDI ARABIA



COMPACT, LOW ENERGY, HIGH PERFORMANCE OIL COOLERS

GERMANY



15% PRODUCTION INCREASE WITH REDUCED CARBON EMISSIONS THROUGH IMPROVED HEAT RECOVERY

RUSSIA



PLANT THROUGHPUT INCREASED BY 47% WHILE AVOIDING FURNACE FIRING LIMIT

CHINA



ADVANCED CONDENSER DESIGN FOR VACUUM DISTILLATION PROCESS

AUSTRALIA



DISTILLATION COLUMN PERFORMANCE IMPROVED BY RESOLVING A REBOILER ISSUE

SOUTH AFRICA



FREQUENT PROCESS UPSETS AVOIDED BY MODIFICATIONS TO CONDENSER OPERATION

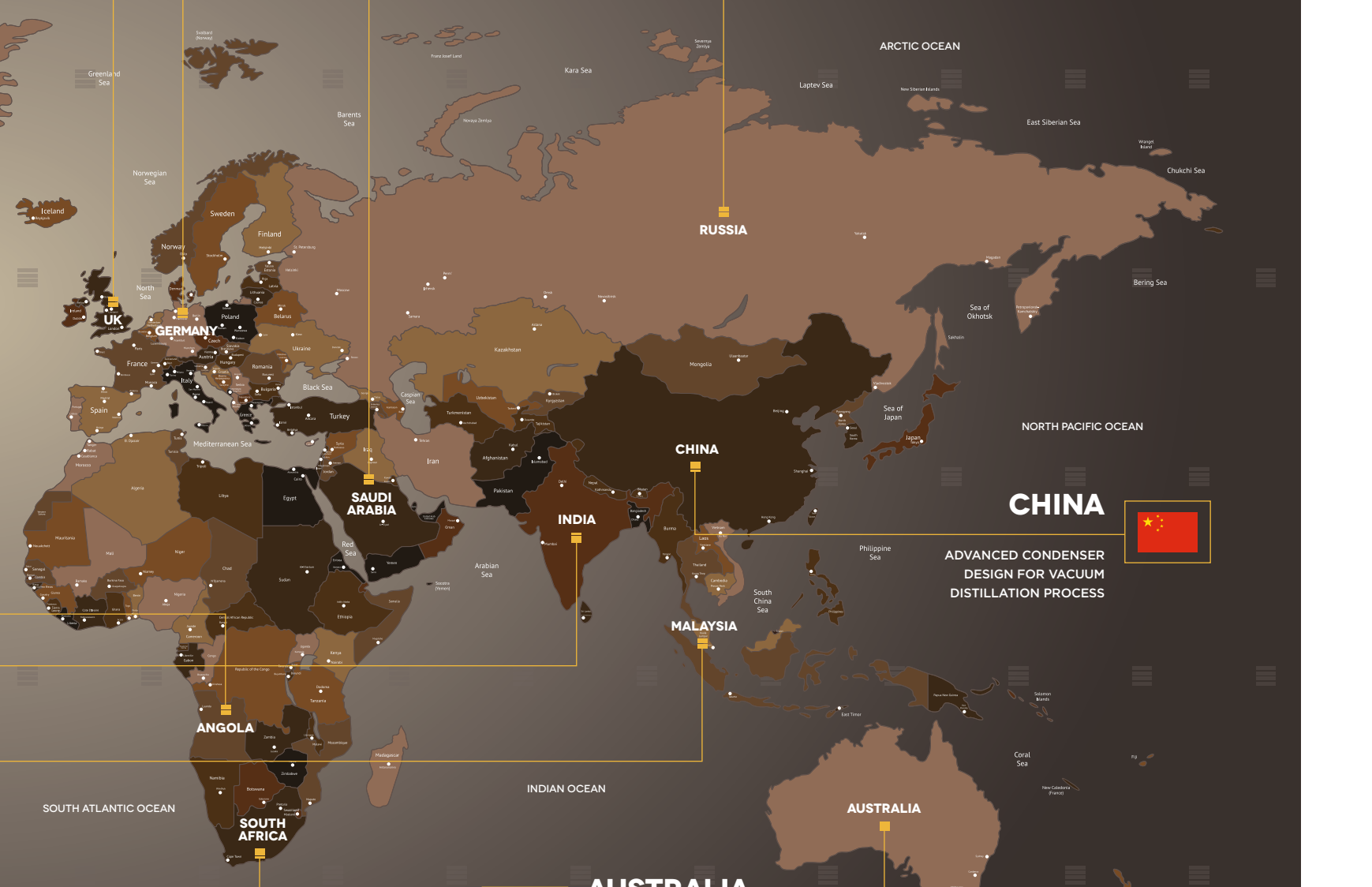

OUR CLIENTS INCLUDE

ADCO - UAE
ADGAS - UAE
ADNOC - FINLAND, UAE
AIR PRODUCTS - UK
AKZONOBEL - NETHERLANDS, ITALY
ALLIED COLLOIDS - UK
ARCO - INDONESIA
ARISTECH CHEMICAL - USA
AVENTIS PHARMA - GERMANY, USA
BASF - BELGIUM, GERMANY, USA, UK
BAYER MATERIALSCIENCE - GERMANY, USA
BHP - AUSTRALIA
BOC - UK
BP AMERICAS - GERMANY
BP CHEMICALS - UK, BELGIUM
BP OIL - CANADA, UK
CABOT - UK, AUSTRALIA, INDONESIA, MALAYSIA
CELANESE - GERMANY
CHEVRON - UK, USA
CHINA PETROLEUM - TAIWAN
CONOCOPHILIPS - UK
CORPOVEN - VENEZUELA, OMAN
COURTAULDS - UK
CRODA - UK
DAICEL CHEMICAL INDUSTRIES - JAPAN
DISTRIGAZ - BELGIUM
DOW - GERMANY, NETHERLANDS, USA, UK
DSM - NETHERLANDS
ELF AQUITAINE - FRANCE
ENGEN - REPUBLIC OF SOUTH AFRICA
ENPPI - EGYPT
EPMI - MALAYSIA
EUROPEAN VINYLs CORPORATION - UK
EXXONMOBIL - CANADA, MALAYSIA, NETHERLANDS, UK, USA
FARAD S.A - GREECE
FARMLAND INDUSTRIES - USA
FMC - USA
GASUNIE - NETHERLANDS
GASCO - UAE
G.E. PLASTICS - NETHERLANDS
HALCARBON PRODUCTS - USA
HENKEL - GERMANY
HERCULES - NETHERLANDS, USA
HÜLS - GERMANY
HUNTSMAN - NETHERLANDS, UK
IMPERIAL OIL - CANADA
INSPEC - UK, NETHERLANDS
INEOS - UK, BELGIUM
KUWAIT PETROLEUM - NETHERLANDS
LANGOVEN - VENEZUELA
LANXESS - GERMANY
LUCITE - UK
LUKOIL - RUSSIA
MALLINCKRODT CHEMICALS - USA
MANRO PRODUCTS - UK
MITSUBISHI CHEMICAL CORPORATION - JAPAN
MITSUBISHI GAS CHEMICAL ENGINEERING - JAPAN
MOBAY - USA
MOBIL OIL - SINGAPORE
MOHAWK OIL - CANADA
NAM (NEDERLANDSE AARDOLIE MAATSCHAPPIJ) - NETHERLANDS
NASR PETROLEUM - EGYPT
NATCO - NETHERLANDS
NATREF - REPUBLIC OF SOUTH AFRICA
NEREFCO (BP/TEXACO) - NETHERLANDS
NORSK HYDRO - NORWAY
NORTH OIL - IRAQ
OCCIDENTAL OIL - COLOMBIA
ONGC - COLOMBIA, INDIA, PAKISTAN
PETROLEUM DEVELOPMENT - OMAN
PEMEX - MEXICO
PETRONAS - MALAYSIA
PETROVIETNAM - VIETNAM
QGPC - QATAR
REPSOL - SPAIN
ROSNEFT - RUSSIA
SASOL - REPUBLIC OF SOUTH AFRICA
SAUDI ARAMCO - KSA
SEVALCO - UK
SHELL - BRUNEI, GERMANY, MALAYSIA, NETHERLANDS,
NEW ZEALAND, NIGERIA, OMAN, UK, USA
SABIC - UK
SINGAPORE REFINING - SINGAPORE
SINOPEC - CHINA
SIRTE OIL - LIBYA
SOFREGAZ - ALGERIA, SYRIA
SONATRACH - ALGERIA
SONELGAZ - ALGERIA
STEPAN - USA
THAI PETROCHEMICAL - THAILAND
TOTAL - INDONESIA, UK, FRANCE, USA
TRANS GAS - CANADA
UBE AMMONIA CORP - JAPAN
UNICHEMA - NETHERLANDS, MALAYSIA
UNILEVER - GERMANY, NETHERLANDS, UK
UNION CARBIDE - CANADA, COLUMBIA, USA
WACKER - GERMANY
WOODSIDE OFFSHORE PETROLEUM - AUSTRALIA

_UK

CALGAVIN LIMITED, MINERVA MILL
STATION ROAD, ALCESTER
WARWICKSHIRE, B49 5ET

_TEL +44 (0) 1789 400401
_FAX +44 (0) 1789 400411
_EMAIL INFO@CALGAVIN.COM

CALGAVIN.COM